

# 2<sup>nd</sup> GRADE

## Week 2

Time	Monday	Tuesday	Wednesday	Thursday	Friday	
8:00	<h1>No School</h1>	<p><b>Learning Warm-Up</b> -Sight Words (Set 7), cut out flashcards and practice reading at least 3 times</p>	<p><b>Learning Warm-Up</b> -Sight Words (set 7) cut out flashcards, add to yesterday's words and practice reading at least 3 times</p>	<p><b>Learning Warm-Up</b> -Sight Words (set 7) cut out flashcards, add to yesterday's words and practice reading at least 3 times</p>	<p><b>Learning Warm-Up</b> -Sight Words (set 7) cut out flashcards, add to yesterday's words and practice reading at least 3 times</p>	
8:30		<p><b>Reading</b> -Daily Reading Comprehension Practice Journal -Read book independently for 15 minutes. Retell the story to a friend or family member</p>	<p><b>Reading</b> -Daily Reading Comprehension Practice Journal -Read book independently for 15 minutes. Retell the story to a friend or family member</p>	<p><b>Reading</b> -Daily Reading Comprehension Practice Journal -Read book independently for 15 minutes. Retell the story to a friend or family member</p>	<p><b>Reading</b> -Daily Reading Comprehension Practice Journal -Read book independently for 15 minutes. Retell the story to a friend or family member</p>	<p><b>Reading</b> -Daily Reading Comprehension Practice Journal -Read book independently for 15 minutes; Retell the story to a friend or family member</p>
9:30		<p><b>Language/Writing</b> -Daily writing; Choose a writing prompt from the April calendar and respond in the Primary Composition Book -Complete Daily Language Practice Journal</p>	<p><b>Language/Writing</b> -Daily writing; Choose a writing prompt from the April calendar and respond in the Primary Composition Book -Complete Daily Language Practice Journal</p>	<p><b>Language/Writing</b> -Daily writing; Choose a writing prompt from the April calendar and respond in the Primary Composition Book -Complete Daily Language Practice Journal</p>	<p><b>Language/Writing</b> -Daily writing; Choose a writing prompt from the April calendar and respond in the Primary Composition Book -Complete Daily Language Practice Journal</p>	<p><b>Language/Writing</b> -Daily writing; Choose a writing prompt from the April calendar and respond in the Primary Composition Book -Complete Daily Language Practice Journal</p>

# 2<sup>nd</sup> GRADE

## Week 2

Time	Monday	Tuesday	Wednesday	Thursday	Friday
10:00		<b>Brain Break</b> Choose a Movement & Mindfulness Break Option	<b>Brain Break</b> Choose a Movement & Mindfulness Break Option	<b>Brain Break</b> Choose a Movement & Mindfulness Break Option	<b>Brain Break</b> Choose a Movement & Mindfulness Break Option
11:00		<b>LUNCH</b>	<b>LUNCH</b>	<b>LUNCH</b>	<b>LUNCH</b>
12:00		<b>Phonics</b> -BossyR Worksheet; Fill in missing letters to complete the word	<b>Phonics</b> -BossyR Sort; Cut out each word and glue in the box.	<b>Phonics</b> -BossyR Sort; Cut out words, sort according if they follow Bossy R rule.	<b>Phonics</b> -Bossy R word sort; Cut out words sort if they sound like storm or curl.
12:30		<b>Math</b> Activity: <a href="#">Measure in Inches and Feet</a> (18.6 Reteach)	<b>Math</b> Khan Academy Video: <a href="#">"Measuring Lengths 2"</a> Activity: <a href="#">Estimate Lengths Using Inches</a> (18.1 Reteach)	<b>Math</b> Khan Academy Video: <a href="#">"Measuring Lengths with Different Units"</a> Activity: <a href="#">Make and Use a Ruler</a> (18.2 Reteach)	<b>Math</b> Activity: <a href="#">Measure to the Nearest Inch</a> (18.3 Reteach)
1:30		<b>Social Studies</b> Work on 'Grandpa and Me' packet and complete one activity to go with the story.	<b>Social Studies</b> Work on 'Grandpa and Me' packet and complete one activity to go with the story.	<b>Social Studies</b> Work on 'Grandpa and Me' packet and complete one activity to go with the story.	<b>Social Studies</b> Work on 'Grandpa and Me' packet and complete one activity to go with the story.
2:00		<b>Music</b> Roll a Rhythm	<b>Art</b> Mo Williams Pigeon and Duckling Puppets	<b>Music</b> Homemade Strummies	<b>Art</b> Photo Journal
2:30		<b>Science</b> Science Journal Activity/Page	<b>Science</b> Science Journal Activity/Page	<b>Science</b> Science Journal Activity/Page	<b>Science</b> Science Journal Activity/Page

No School

# Family and Student Supports:

<p>Please review family letters for these content area assignments:</p> <ul style="list-style-type: none"><li>• Literacy</li><li>• Math</li><li>• Science</li><li>• Social Studies</li><li>• Art</li><li>• Music</li></ul>	<h3>Student Learning Kits</h3> <p><u>Supplies:</u> ruler, crayons, pencils, glue sticks, scissors, paper, markers, composition book</p> <p><u>Math:</u> Daily Math Practice Journal</p> <p><u>Literacy:</u> Daily Interactive Reading Comprehension Journal, Writing Prompt Journal, Daily Language Practice Book, Interactive Phonics Activities/Journal</p> <p><u>Science:</u> Daily Science Activity &amp; Journal</p> <p><u>Art:</u> watercolor paint, paper</p>
--	--

# Additional Student Supports:

<b>Individual Supports</b>	Please reference the “Helping Your Child at Home in Reading” and “Helping Your Child at Home in Math” documents shared as well as the <i>Individual Supports</i> packet of information for additional access to individual student supports as needed.
<b>English Language Learners</b>	Please reference the <i>Academic Enrichment Packet for English Language Learners</i> to access additional student supports as needed.

*Please reach out to your child's school if you have any questions or need assistance with login information.*

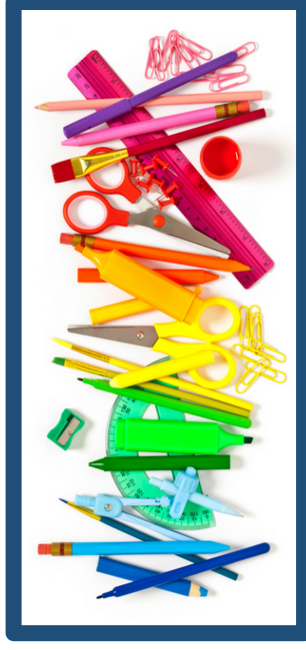

# Online Learning:

Resource	Access Information
<p><b>Imagine Learning – Literacy</b> Online learning for literacy – 30 minutes daily (may replace portion of Reading block)</p>	<p><b>Accessible through Clever</b> (Found on CMSD website student page)</p>
<p><b>Imagine Learning – Math</b> Online learning for math - 30 minutes daily (may replace Math block)</p>	<p><b>Accessible through Clever</b> (Found on CMSD website student page)</p>
<p><b>BrainPop Junior</b> Online video clips that can be used for learning in all subject areas.</p>	<p><a href="https://jr.brainpop.com/">https://jr.brainpop.com/</a></p>
<p><b>Scholastic Learn at Home</b> Access to books and read alouds along with literacy lessons to use at home.</p>	<p><a href="http://www.scholastic.com/learnathome">http://www.scholastic.com/learnathome</a> Username: Learning20 Password: Clifford</p>
<p><b>ExactPath (access through Clever)</b> Individualized instruction linked to student data that allows students to learn content as appropriate (intervention and enrichment supports)</p>	<p><b>Accessible through Clever</b> (Found on CMSD website student page)</p>
<p><b>Second and Seven Read Alouds</b> Online read alouds for grades K-2. No login is needed.</p>	<p><a href="https://kids.secondandseven.com/">https://kids.secondandseven.com/</a></p>
<p><b>Khan Academy</b> Digital Math Instruction Videos – Free login</p>	<p><a href="https://www.khanacademy.org/">https://www.khanacademy.org/</a></p>

# Movement & Mindfulness Break Options:

Outside Play Activities	Playground Visit
<p>Go Noodle <a href="https://family.gonoodle.com/">https://family.gonoodle.com/</a></p>	<p>Go for a Run or Walk (with an adult)</p>
<p>The OT Toolbox <a href="https://www.theottoolbox.com/best-brain-breaks-videos-on-youtube/">https://www.theottoolbox.com/best-brain-breaks-videos-on-youtube/</a></p>	<p>Fluency and Fitness (free for 3 wks) <a href="https://fluencyandfitness.com/">https://fluencyandfitness.com/</a></p>
<p>Mind Yeti <a href="https://www.mindyeti.com">https://www.mindyeti.com</a></p>	<p>Positive Psychology <a href="https://positivepsychology.com/mindfulness-for-children-kids-activities/">https://positivepsychology.com/mindfulness-for-children-kids-activities/</a></p>
<p>Calm (app available also) <a href="https://www.calm.com/schools">https://www.calm.com/schools</a></p>	<p>Teach, Train, Love <a href="http://teachtrainlove.com/20-brain-break-clips-fight-the-fidgeting/">http://teachtrainlove.com/20-brain-break-clips-fight-the-fidgeting/</a></p>





Exact Path



Study Island

**edmentum™**

Dear Students & Families:

CMSD offers instruction through the programs Exact Path and Study Island. Exact Path includes K-12 assessment-driven math, reading, and language arts instruction; and Study Island provides instruction and assessments in math, reading, English Language arts, science, and social studies. The videos below are designed to assist with navigating both Exact Path and Study Island while working from home. Each video is approximately 10-15 minutes in length.

Please note that students access Exact Path through the CMSD Clever student portal using the login credentials they have been using all school year. The CMSD portal can be reached from this link:

<https://www.clevelandmetroschools.org/Page/15212>

As you will see, each video is specific to the grade range listed in the title.

[Exact Path & Study Island at Home: Grades K-2nd](#)

[Exact Path & Study Island at Home: Grades 3rd-5th](#)

[Exact Path & Study Island at Home: Grades 6th-12th](#)

Thank you,  
The Academic Offices  
Cleveland Metropolitan School District





## Daily Assignments Checklist

Name: \_\_\_\_\_ Week: \_\_\_\_\_

Dear Parents/Guardians,

In the work packet, you will find assignments for the below subjects. Most often there will be more than one assignment for a subject area. After your child completes the assignment(s) in each area, he/she should place a check in the box. This checklist will help your child monitor his/her completion of tasks, as well as promote responsibility. --Thank you!

Assignments	Mon.	Tues.	Wed.	Thurs.	Fri.
Learning Warm-Up					
Reading					
Language/ Writing					
Phonics					
Math					
Social Studies					
Art or Music					
Science					

April Writing Prompts

Sunday	Monday	Tuesday	Wednesday	Thursday	Friday	Saturday
1	2	3	4	5	6	7
8	9	10	11	12	13	14
15	16	17	18	19	20	21
22	23	24	25	26	27	28
29	30	1	2	3	4	5



# 2<sup>nd</sup> GRADE

## Writing Prompts

Dear Parents/Guardians,

Every day, your child will respond to a writing prompt from the **April Writing Prompts Calendar**. This calendar is included in the work packet.





With your support, your child will complete the following tasks:

1. Locate the date on the calendar.
2. Read and discuss the prompt with you.
3. Write 3-4 sentences responding to the prompt in the Primary Composition Book.
4. Read and reread his/her work to check if it makes sense, and for correct capitalization and punctuation.
5. Your child may draw and color a picture if he/she chooses.

Thank you

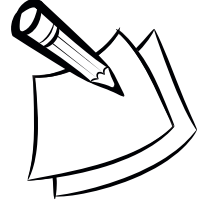

# April Writing Prompts

Sunday	Monday	Tuesday	Wednesday	Thursday	Friday	Saturday
					It's April Fool's Day! What joke have you played or would you play on your friends?	Spring is a time of new beginnings. What activity would you like to begin?
<b>3</b> Write a story about a marshmallow bunny that comes to life.	<b>4</b> Describe your favorite thing to do at recess.	<b>5</b> Pretend you are an animal in the zoo. Write about the day you escape!	<b>6</b> The best thing to do on a rainy day is...	<b>7</b> If you could pick a new name for yourself, what would it be and why?	<b>8</b> Pretend you are an umbrella! Write about your day in the rain.	<b>9</b> Would you rather be as big as a giant or as small as a mouse?
<b>10</b> If you could add a new school subject, what would it be and why?	<b>11</b> In spring, I love the smell of...	<b>12</b> Write a funny story about the day it rained chocolate chips!	<b>13</b> If I could be a butterfly for a day...	<b>14</b> If you could eat anything for breakfast, what would it be and why?	<b>15</b> Imagine you move to a new city. How would you make new friends?	<b>16</b> Tell about a time you felt proud of yourself or someone in your family.
<b>17</b> Imagine you could be anyone else for one day! Who would it be and why?	<b>18</b> Pretend you bumped into someone famous! Write a dialogue of your conversation.	<b>19</b> List five things you like about your pet—or a pet you wish you had.	<b>20</b> Write a poem about a rainy day.	<b>21</b> Imagine you found an old treasure map. Where does it lead and what do you find there?	<b>22</b> Today is Earth Day. What are three things you can do to help protect our planet?	<b>23</b> One spring day, I hopped into a hot air balloon and floated off to...
<b>24</b> If you were a tour guide for your city, where would you take visitors? Why?	<b>25</b> Imagine you are building a giant tree house. What does it look like?	<b>26</b> Make a list of 10 items you would need to take to a sleepover.	<b>27</b> Imagine you found a golden key. What does it open and what do you see there?	<b>28</b> My favorite memory of my class this year is...	<b>29</b> In spring, I love the smell of...	<b>30</b> If you could donate a million dollars to any charity, which would it be and why?
						

Name: \_\_\_\_\_

Date: \_\_\_\_\_

# Missing Bossy R Sounds

Fill in the missing letters of these *bossy r* (r-controlled) words with: **er, or, ur, ar, or ir.**

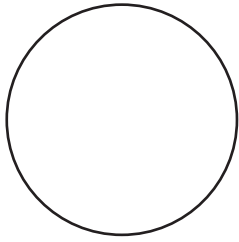

c\_\_cle

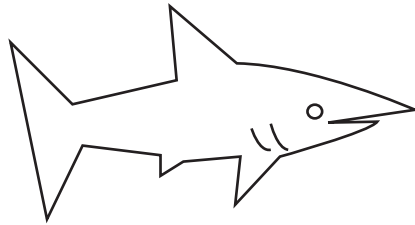

sh\_\_k

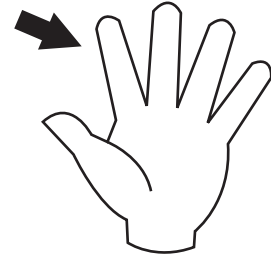

fing\_\_

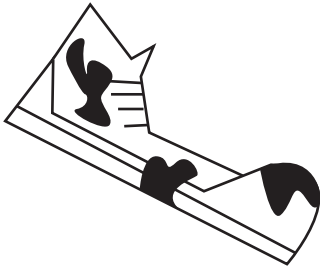

d\_\_ty

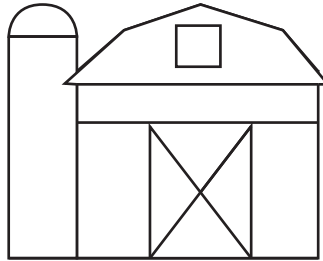

f\_\_m

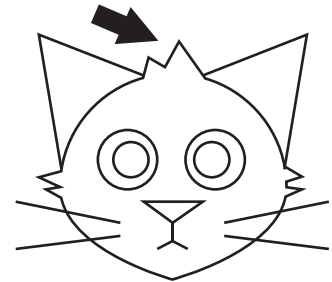

f\_\_

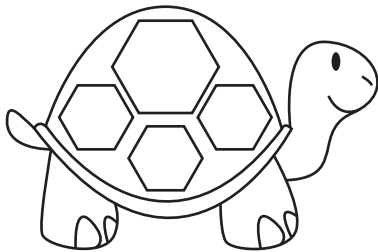

t\_\_tle

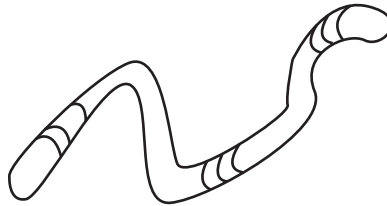

w\_\_m

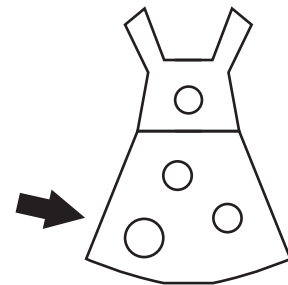

sk\_\_t



st\_\_m

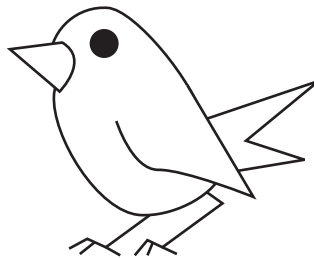

b\_\_d

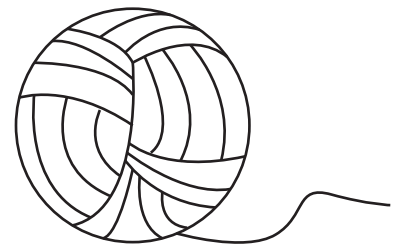

y\_\_n

Most Common Words • Set 7

much

Reading A-Z

Most Common Words • Set 7

write

Reading A-Z



Most Common Words • Set 7

try

Reading A-Z

Most Common Words • Set 7

keep

Reading A-Z

Most Common Words • Set 7

white

Reading A-Z

Most Common Words • Set 7

new

Reading A-Z

# Bossy R Sort

Cut out each word glue it in the box with the matching Bossy R sound.

-ir

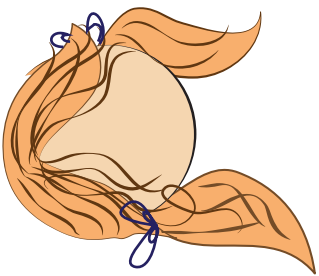

-ar

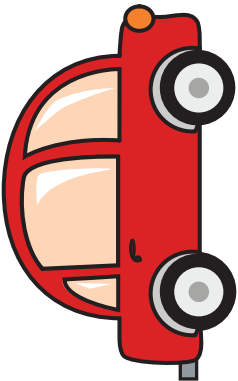

-er

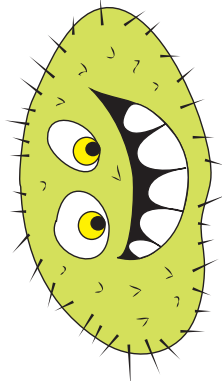

-or

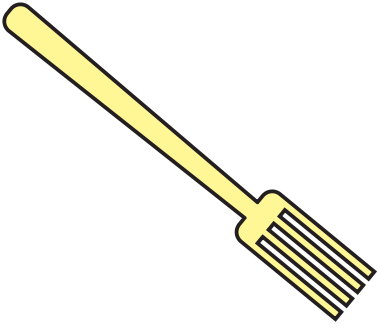

cord	star	borrow	bear
chair	door	their	card
alarm	fern	bird	purse

Most Common Words • Set 7

ten

Reading A-Z

Most Common Words • Set 7

must

Reading A-Z



Most Common Words • Set 7

always

Reading A-Z

Most Common Words • Set 7

does

Reading A-Z

Most Common Words • Set 7

give

Reading A-Z

Most Common Words • Set 7

drink

Reading A-Z

# Syllables

In "R-Controlled" syllable words, a vowel is followed by the letter "R".

HINT: The "R" gives the vowel a different sound.

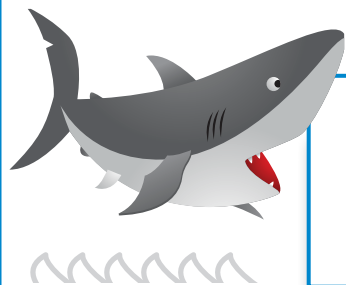

R-Controlled

Not R-Controlled





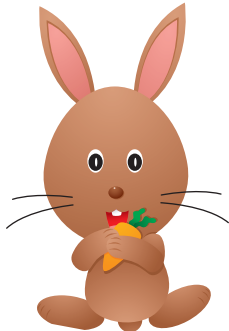
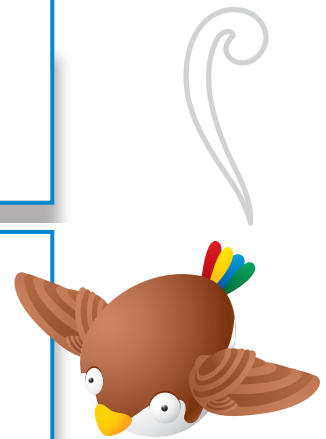

Cut out the name of each word. Read each word out loud. Does the word follow the "R Controlled" rule? Paste each word in the correct column below.



turkey

run

baker

rabbit

pretty

shark

rough

bird

Most Common Words • Set 7

work

Reading A-Z

Most Common Words • Set 7

once

Reading A-Z



Most Common Words • Set 7

start

Reading A-Z

Most Common Words • Set 7

soon

Reading A-Z

Most Common Words • Set 7

bring

Reading A-Z

Most Common Words • Set 7

has

Reading A-Z

 Reading a-z Word Sort

R-controlled /o/, R-controlled /ur/

Sounds like  
/ô/ in *storm*

Sounds like  
/ûr/ in *curl*

roar

urge

dirt

before

learn

thorn

sort

clerk

porch

fir

birth

four



Most Common Words • Set 7

our

Reading A-Z

Most Common Words • Set 7

find

Reading A-Z



Most Common Words • Set 7

warm

Reading A-Z

Most Common Words • Set 7

better

Reading A-Z

Most Common Words • Set 7

made

Reading A-Z

Most Common Words • Set 7

ate

Reading A-Z

Name \_\_\_\_\_

# Measure in Inches and Feet

You can measure objects in inches or feet.

A clipboard is about 12 inches long.

A clipboard is also about 1 foot long.

12 inches is the same as 1 foot.

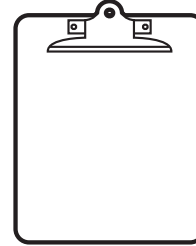

Use an inch ruler to measure the objects. Measure in inches.  
 Then measure in feet.

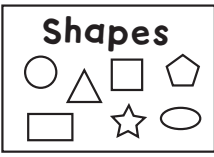
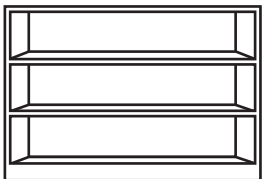
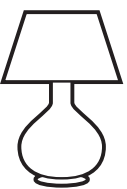
Find the real object.	Measure.
<b>1</b> poster 	_____ inches _____ feet
<b>2</b> bookshelf 	_____ inches _____ feet
<b>3</b> lamp 	_____ inches _____ feet

**4** Did you use more inches or more feet to measure the length of the objects?

more \_\_\_\_\_

© Houghton Mifflin Harcourt Publishing Company

Name \_\_\_\_\_



**ONLINE**  
Video Tutorials and  
Interactive Examples

## Measure in Inches and Feet

- 1 Use Tools** Use an inch ruler to measure the length of a banner or another large item to the nearest inch. Then measure its length to the nearest foot.

**WELCOME TO 2<sup>ND</sup> GRADE!**

\_\_\_\_\_ inches

\_\_\_\_\_ feet

- 2** Use an inch ruler to measure the length of a counter to the nearest inch. Then measure its length to the nearest foot.

\_\_\_\_\_ inches

\_\_\_\_\_ feet

- 3** Madison has a ribbon that is 6 feet long. Jason has a ribbon that is 6 inches long. Who has the shorter piece of ribbon? How do you know?

\_\_\_\_\_

\_\_\_\_\_

\_\_\_\_\_

## Test Prep

- 4 Write Inches or Feet to make the sentence true.

A jump rope is 6 \_\_\_\_\_ long.

A toy train is 10 \_\_\_\_\_ long.

A countertop is 60 \_\_\_\_\_ long.

- 5 Abby's string is 5 inches long. Isaiah's string is 5 feet long. Who has the longer string? Circle the correct answer.

Abby          Isaiah

## Spiral Review

- 6 Harrison and Katie have 20 markers in all. They each have the same number of markers. How many markers do Harrison and Katie each have? Write an addition equation to show the equal groups. Solve.

\_\_\_\_\_ = \_\_\_\_\_ + \_\_\_\_\_          \_\_\_\_\_ markers

Write an addition equation to show the number as the sum of two equal addends.

- 7 12

\_\_\_\_\_ = \_\_\_\_\_ + \_\_\_\_\_

- 8 8

\_\_\_\_\_ = \_\_\_\_\_ + \_\_\_\_\_

Name \_\_\_\_\_

## Measure to the Nearest Yard

You can use a yardstick to measure and estimate lengths.

Use the 3 yardsticks in the picture to measure the flags to the nearest yard. Write the number of yards.

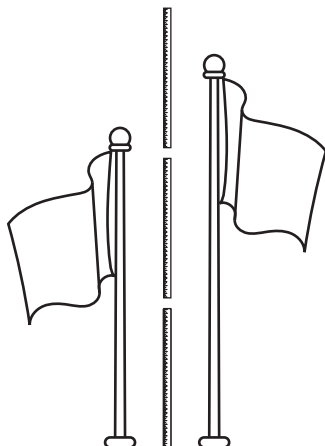

The flag pole on the left is a little taller than two yardsticks.

\_\_\_\_\_ 2 \_\_\_\_\_ yards

The flag pole on the right is almost as tall as three yardsticks.

\_\_\_\_\_ 3 \_\_\_\_\_ yards

Use the pictures of the yardsticks to estimate the length of each object.

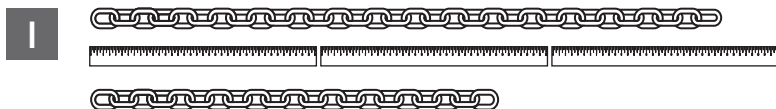

\_\_\_\_\_ 3 \_\_\_\_\_ yards

\_\_\_\_\_ yards

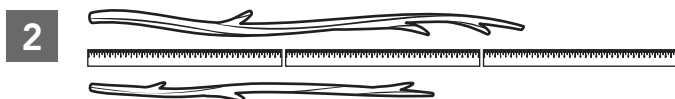

\_\_\_\_\_ yards

\_\_\_\_\_ yards

Name \_\_\_\_\_

 **ONLINE**  
Video Tutorials and  
Interactive Examples

# Measure to the Nearest Yard

**1**  **Reason** About how many yards long is a teacher's desk?



Estimate: \_\_\_\_\_ yards

**2** Choose a large item. Estimate the length in yards. Then measure the length in yards. Draw and label it.

Estimate: \_\_\_\_\_ yards

Measure: \_\_\_\_\_ yards

**MP** **Use Tools** Find each object. Use a yardstick to measure to the nearest yard. Write the length to the nearest yard.

**3** mat



\_\_\_\_\_ yards

**4** countertop

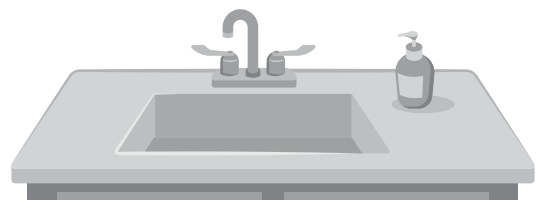

\_\_\_\_\_ yards

## Test Prep

5 About how many yards long is a school bus? Fill in the bubble next to the correct answer.

- 2 yards
- 4 yards
- 15 yards

6 How many 12-inch rulers are needed to match the length of 1 yardstick?



\_\_\_\_\_ 12-inch rulers

7 Devin measures a bike with a yardstick. About how many yards long is Devin's bike? Fill in the bubble next to the correct answer.

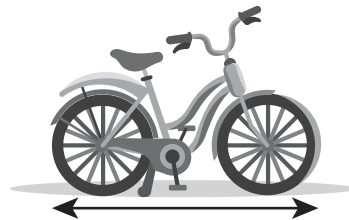

- 1 yard       2 yards       5 yards

## Spiral Review

8 Emma has 34 crayons. Tabitha has 28 crayons. How many crayons do they still need if they want a total of 70 crayons? Write two equations. Solve.

\_\_\_\_\_

\_\_\_\_\_

Emma and Tabitha still need \_\_\_\_\_ crayons.

Name \_\_\_\_\_

## Choose Appropriate Tools

You can use different tools to measure lengths.

Use an inch ruler to measure objects with shorter lengths.



Use a yardstick to measure objects with longer lengths.



Use a measuring tape to measure curved objects.

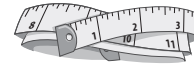

Choose the best tool for measuring the real object.  
Then measure and record the length.

1 a lunch box



Tool: ruler

Length: \_\_\_\_\_

2 a basketball



Tool: \_\_\_\_\_

Length: \_\_\_\_\_



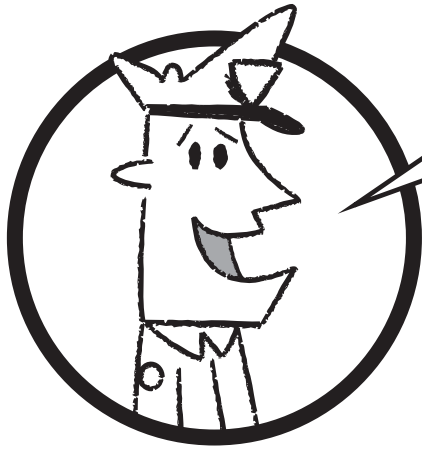

Let's make Pigeon and Duckling puppets!

Just follow these simple steps. **You will need:**



CRAYONS



SCISSORS



TAPE

**1** Print this PDF.

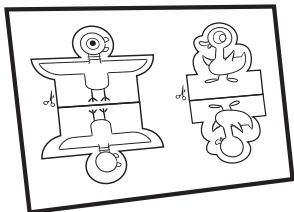

**2** Color the puppets.

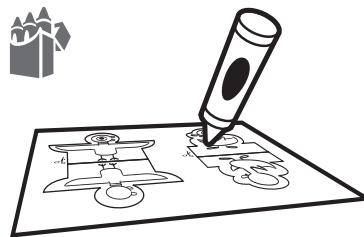

**3** Cut along the dashed lines to cut out the puppets.

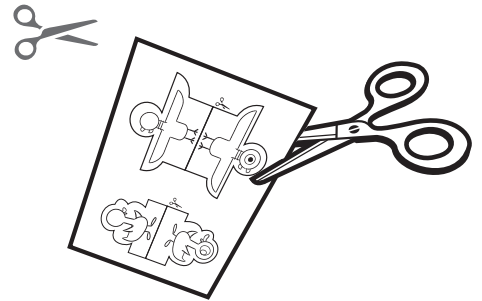

**4** Fold each puppet in half along the black solid line.

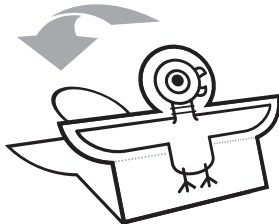

**5** Cut along the dotted lines.

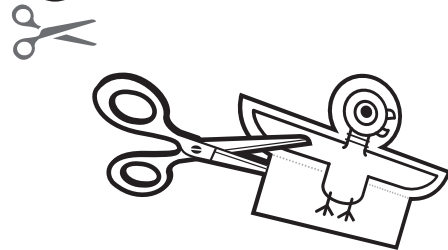

**6** Roll the bottom into a tube so that the arrows touch; then, tape it together. It should be a little bit bigger than your finger.

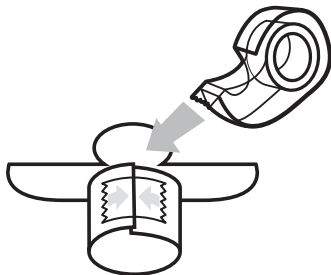

**7** Yay! You just made finger puppets!

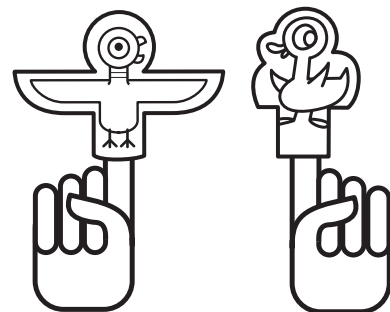

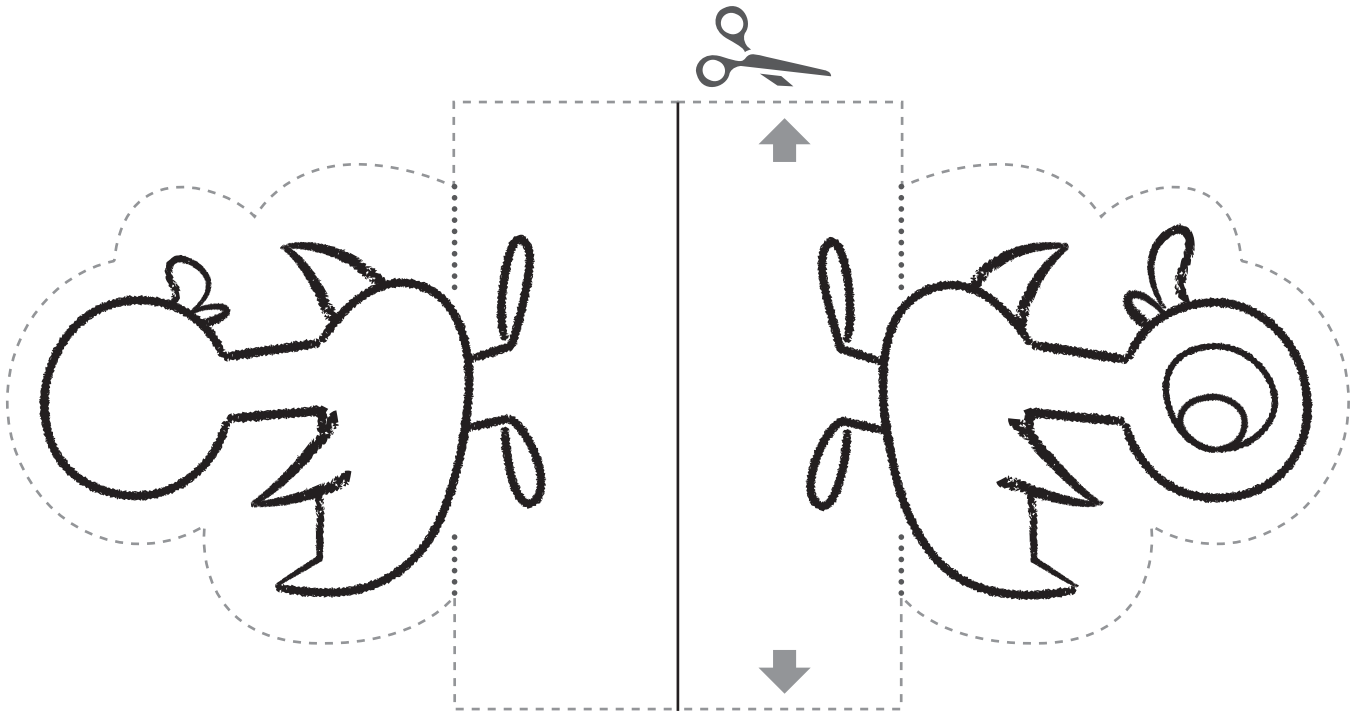
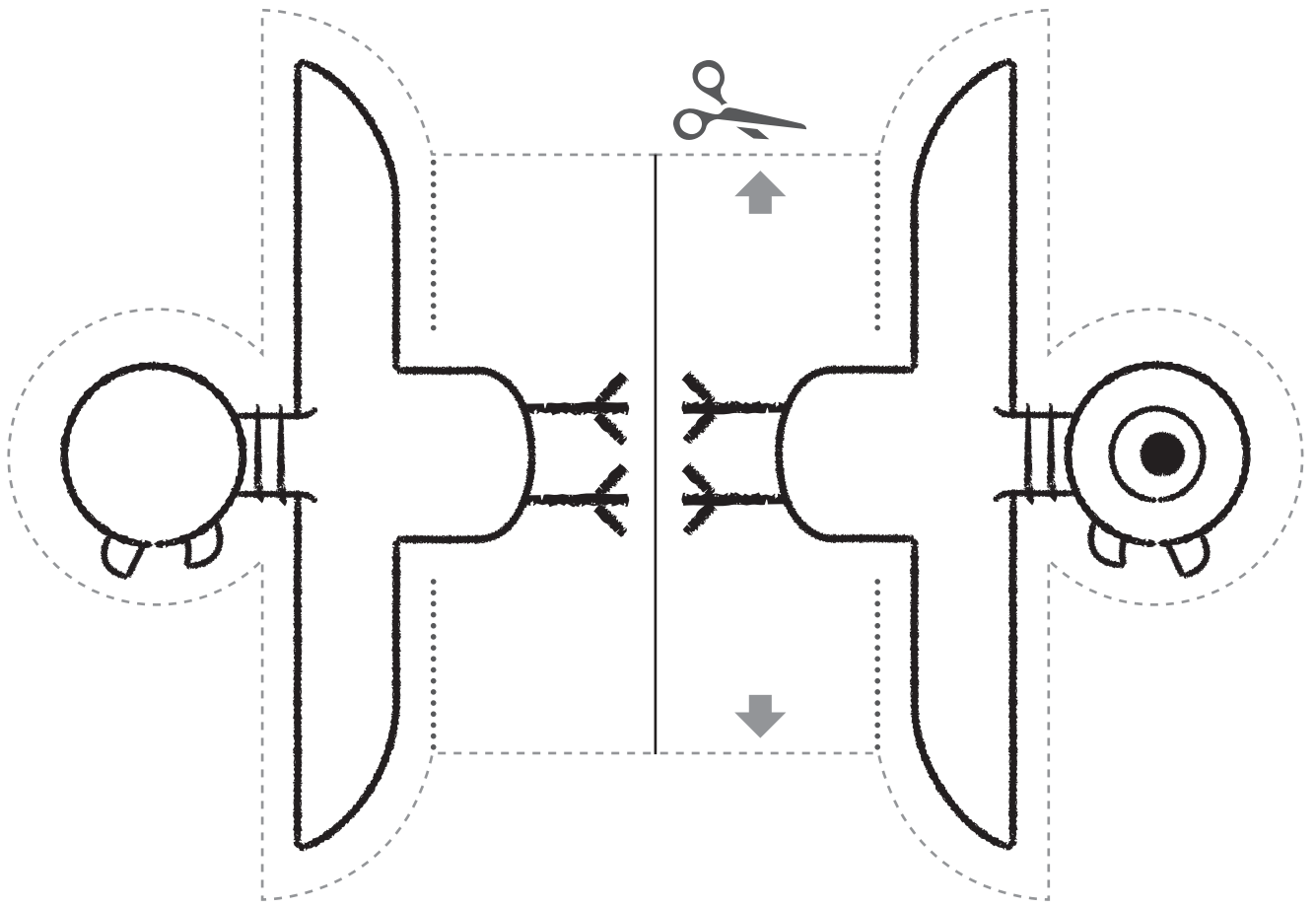

# Gr 1 week 2 Day 4 Homemade Strummies

What you will need:

- Any size box (small is best for smaller hands!)
- A variety of rubber bands
- Markers/crayons to decorate



The children added rubber bands around the boxes to create the strings for the strummies. The children discovered that the smaller the rubber bands, the better the sound so they sorted through all sizes of rubber bands to find the smallest ones available.



## Exploring Sound and Vibration

To play a strummy, you simply pluck or strum your finger across the strings. Before heading off to make our strummies, the children explored a set of strummies I had already made and we talked together about the different sounds the strummy makes when you strum versus pluck the strings of the strummies.